

HS1C Interlock Switches with Solenoid

The guard door remains locked until the machine stops completely.

- With the actuator mounted on the guard door and the interlock switch on the machine, the door is mechanically locked when closed.
- The door is unlocked by a solenoid lock-release signal from a PLC or another source after the machine has stopped, ensuring higher safety.
- In the event of power failure or for machine maintenance, the door can be unlocked using a special tool.
- Flexible installation: The actuator can be inserted into two directions.
- Select from four different circuit configurations.
- IP67 rated rugged die-cast aluminum housing.



Parts and Functions

- Two Conduit Ports (G1/2)
Use IP67 conduit or gland
(see page 112 for details).



- LED Indicator
(green or red)

- Straight Actuator
(SUS304)



- Right-angle Actuator
(SUS304)



- Angle Adjustable Actuator
for hinged doors

- Manual Unlocking Entry (M4 hole)
Accessible using a small screwdriver
after removing a TORX screw on the un-
locking entry

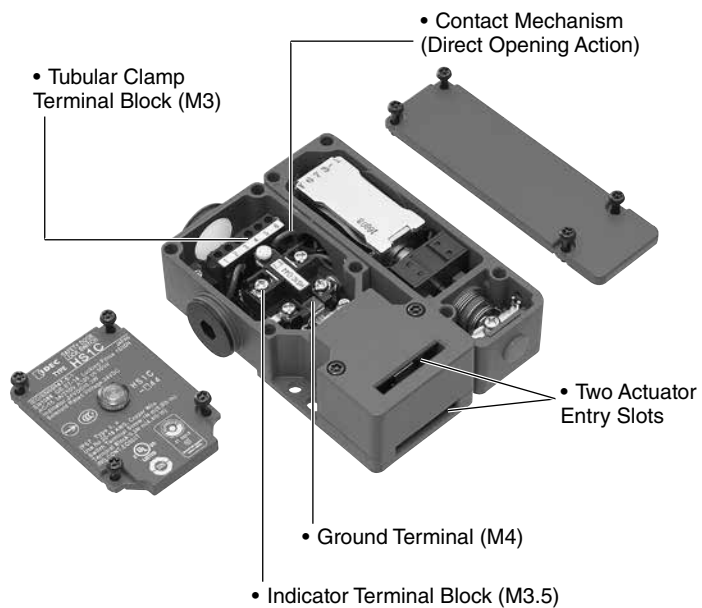

- Tubular Clamp
Terminal Block (M3)

- Contact Mechanism
(Direct Opening Action)

- Two Actuator
Entry Slots

- Ground Terminal (M4)

- Indicator Terminal Block (M3.5)

HS1C Interlock Switches with Solenoid

Interlock Switch

Contact Configuration	Solenoid Unit Location	Part No.
Main Circuit: 1NC+1NC Auxiliary Circuit: 1NO/1NO 	Right	HS1C-R44R-②
Main Circuit: 1NC+1NC Auxiliary Circuit: 1NO 	Right	HS1C-R144R-②
Main Circuit: 1NC+1NC Auxiliary Circuit: 1NC+1NC 	Right	HS1C-R244R-②
Main Circuit: 1NC+1NC Auxiliary Circuit: 1NC 	Right	HS1C-R344R-②

- The contact configurations show the contact status when the actuator is inserted and locked.
- The HS9Z-T1 special key wrench for removing the cover and manual unlocking is supplied with the interlock switch.
- Specify an indicator color in place of ② in the Part No.
G: green, R: red
- The solenoid unit installed on the left can be made upon request.
- Actuators are not supplied with the interlock switch, and must be ordered separately.

Actuators/Key Wrench/Screwdriver for TORX Screws

Description	Part No.
Straight Actuator	HS9Z-A1
Right-angle Actuator	HS9Z-A2
Angle Adjustable Actuator (mainly for hinged doors)	HS9Z-A3
Special Key Wrench for TORX	HS9Z-T1

Part No. Development

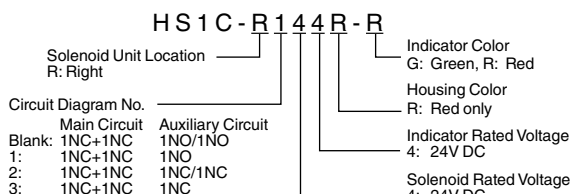

Contact Ratings

Rated Insulation Voltage (Ui)		300V (between LED or solenoid and ground: 60V)				
Rated Thermal Current (Ith)		Main circuit: 10A Auxiliary circuit: 3A				
Rated Voltage (Ue)		30V	125V	250V		
Rated Current (Ie) (Note)	Main Circuit	AC	Resistive load (AC-12)	10A	10A	6A
			Inductive Load (AC-15)	10A	5A	3A
	Auxiliary Circuit	DC	Resistive load (DC-12)	6A	—	—
			Inductive Load (DC-13)	3A	0.9A	—
Main Circuit	AC	Resistive load (AC-12)	—	3A	3A	
		Inductive Load (AC-15)	—	—	3A	
Auxiliary Circuit	DC	Resistive load (DC-12)	3A	—	—	
		Inductive Load (DC-13)	—	0.9A	—	

- Minimum applicable load (reference value): 3V AC/DC, 5 mA
- Note: Ratings approved by safety agencies: A300: AC-15 3A/250V

Solenoid Unit

Rated Voltage	24V DC (100% duty cycle)
Rated Current	415 mA
Coil Resistance	58Ω (at 20°C)
Pickup Voltage	Rated voltage × 85% maximum (at 20°C)
Dropout Voltage	Rated voltage × 10% minimum (at 20°C)
Maximum Continuous Applicable Voltage	Rated voltage × 110%
Maximum Continuous Applicable Time	Continuous
Insulation Class	Class B

Indicator

Rated Voltage	24V DC
Rated Current	10 mA
Light Source	LED
Light Color	G (green), R (red)

- The lens cannot be replaced.

Specifications

Applicable Standards	ISO14119, EN1088, IEC60947-5-1 EN60947-5-1 (TUV approved) GS-ET-19 (TUV approved) UL508 (UL listed) CSA C22.2 No.14 (c-UL listed) GB14048.5 (CCC approved) IEC 60204-1/EN 60204-1 (applicable standards for use)
Operating Temperature	-20 to 50°C (no freezing)
Relative Humidity	45 to 85% (no condensation)
Storage Temperature	-40 to +80°C (no freezing)
Pollution Degree	3
Impulse Withstand Voltage	4 kV (between LED, solenoid and ground: 2.5 kV)
Insulation Resistance (500V DC megger)	Between live and dead metal parts: 100 MΩ minimum Between live metal part and ground: 100 MΩ minimum Between live metal parts: 100 MΩ minimum Between terminals of the same pole: 100 MΩ minimum
Electric Shock Protection	Class I (IEC 61140)
Degree of Protection	IP67 (IEC 60529)
Shock Resistance	Damage limits: 1000 m/s ²
Vibration Resistance	Operating extremes: 10 to 55 Hz, amplitude 0.5 mm minimum Damage limits: 30 Hz, amplitude 1.5 mm minimum
Actuator Operating Speed	0.05 to 1.0 m/s
Direct Opening Travel	11 mm minimum
Direct Opening Force	20N minimum
Actuator Retention Force	1500N minimum (GS-ET-19)
Operating Frequency	900 operations per hour
Mechanical Life	1,000,000 operations minimum (GS-ET-19)
Electrical Life	100,000 operations minimum (operating frequency 900 operations per hour, load AC-12, 250V, 6A) 1,000,000 operations minimum (operating frequency 900 operations per hour, load 24V AC/DC, 100mA)
Conditional Short-circuit Current	100A (250V) (Use 250V/10A fast-blow fuse for short-circuit protection.)
Weight (approx.)	660g

HS1C Interlock Switches with Solenoid

Circuit Diagrams and Operating Characteristics

HS1C-□4□□R-* (Main Circuit: 1NC+1NC, Monitor Circuit: 1NO/1NO)

	Status 1	Status 2	Status 3	Status 4
Interlock Switch Status	<ul style="list-style-type: none"> • Door closed • Machine ready to operate • Solenoid de-energized 	<ul style="list-style-type: none"> • Door closed • Machine cannot be started • Solenoid energized 	<ul style="list-style-type: none"> • Door open • Machine cannot be started • Solenoid energized 	<ul style="list-style-type: none"> • Door open • Machine cannot be started • Solenoid de-energized
Door				
Circuit Diagram	<p>Contacts are linked to the solenoid mechanically.</p>	<p>Contacts are linked to the solenoid mechanically.</p>	<p>Contacts are linked to the solenoid mechanically.</p>	<p>Contacts are linked to the solenoid mechanically.</p>
Main Circuit	3-4: Closed	3-4: Open	3-4: Open	3-4: Open
Monitor Circuit	1-2: Open	1-2: Closed	1-2: Closed	1-2: Closed
Solenoid Power	5-6: Power OFF	5-6: Power ON	5-6: Power ON	5-6: Power OFF

HS1C-□14□□R-* (Main Circuit: 1NC+1NC, 1NC+1NC, Monitor Circuit: 1NO)

	Status 1	Status 2	Status 3	Status 4
Interlock Switch Status	<ul style="list-style-type: none"> • Door closed • Machine ready to operate • Solenoid de-energized 	<ul style="list-style-type: none"> • Door closed • Machine cannot be started • Solenoid energized 	<ul style="list-style-type: none"> • Door open • Machine cannot be started • Solenoid energized 	<ul style="list-style-type: none"> • Door open • Machine cannot be started • Solenoid de-energized
Door				
Circuit Diagram	<p>Contacts are linked to the solenoid mechanically.</p>	<p>Contacts are linked to the solenoid mechanically.</p>	<p>Contacts are linked to the solenoid mechanically.</p>	<p>Contacts are linked to the solenoid mechanically.</p>
Main Circuit	3-4: Closed	3-4: Open	3-4: Open	3-4: Open
Monitor Circuit	1-2: Open	1-2: Open	1-2: Closed	1-2: Closed
Solenoid Power	5-6: Power OFF	5-6: Power ON	5-6: Power ON	5-6: Power OFF

- Main circuit: Connected to the machine drive control circuit, sending interlock signals to the protective door.
- Monitor circuit: Sends ON/OFF signals of the main circuit and monitoring signals of open/closed status of the protective door.

HS1C Interlock Switches with Solenoid

HS1C-□24□□R-* (Main Circuit: 1NC+1NC, Monitor Circuit: 1NC/1NC)

Interlock Switch Status	Status 1	Status 2	Status 3	Status 4
	Door	<ul style="list-style-type: none"> Door closed Machine ready to operate Solenoid de-energized 	<ul style="list-style-type: none"> Door closed Machine cannot be started Solenoid energized 	<ul style="list-style-type: none"> Door open Machine cannot be started Solenoid energized
Circuit Diagram	<p>Contacts are linked to the solenoid mechanically.</p>	<p>Contacts are linked to the solenoid mechanically.</p>	<p>Contacts are linked to the solenoid mechanically.</p>	<p>Contacts are linked to the solenoid mechanically.</p>
Main Circuit	3-4: Closed	3-4: Open	3-4: Open	3-4: Open
Monitor Circuit	1-2: Closed	1-2: Open	1-2: Open	1-2: Open
Solenoid Power	5-6: Power OFF	5-6: Power ON	5-6: Power ON	5-6: Power OFF

HS1C-□34□□R-* (Main Circuit: 1NC+1NC, Monitor Circuit: 1NC)

Interlock Switch Status	Status 1	Status 2	Status 3	Status 4
	Door	<ul style="list-style-type: none"> Door closed Machine ready to operate Solenoid de-energized 	<ul style="list-style-type: none"> Door closed Machine cannot be started Solenoid energized 	<ul style="list-style-type: none"> Door open Machine cannot be started Solenoid energized
Circuit Diagram	<p>Contacts are linked to the solenoid mechanically.</p>	<p>Contacts are linked to the solenoid mechanically.</p>	<p>Contacts are linked to the solenoid mechanically.</p>	<p>Contacts are linked to the solenoid mechanically.</p>
Main Circuit	3-4: Closed	3-4: Open	3-4: Open	3-4: Open
Monitor Circuit	1-2: Closed	1-2: Closed	1-2: Open	1-2: Open
Solenoid Power	5-6: Power OFF	5-6: Power ON	5-6: Power ON	5-6: Power OFF

- Main circuit: Connected to the machine drive control circuit, sending interlock signals to the protective door.
- Monitor circuit: Sends ON/OFF signals of the main circuit and monitoring signals of open/closed status of the protective door.

HS1C Interlock Switches with Solenoid

Safety Precautions

- In order to avoid electric shock or fire, turn power off before installation, removal, wire connection, maintenance, or inspection of the interlock switch.
- If relays are used in the circuit between the interlock switch and the load, consider the danger and use safety relays, since welded or sticking contacts of standard relays may invalidate the functions of the interlock switch. Perform risk assessment and establish a safety circuit which satisfies the requirement of the safety category.
- Do not place a PLC in the circuit between the interlock switch and the load. Safety security can be endangered in the event of a malfunction of the PLC.
- Do not disassemble or modify the interlock switch, otherwise a malfunction or an accident may occur.
- Do not install the actuator in the location where the human body may come into contact. Otherwise injury may occur.

Instructions

- Regardless of door types, do not use the interlock switch as a door stop. Install a mechanical door stop at the end of the door to protect the interlock switch against excessive force.
- Do not apply excessive shock to the interlock switch when opening or closing the door. A shock to the interlock switch exceeding $1,000 \text{ m/s}^2$ may cause damage to the interlock switch.
- When wiring, unscrew the cover with part number label only. Unnecessary loosening of other screws may cause a malfunction of the interlock switch.
- Prevent foreign objects such as dust and liquids from entering the interlock switch while connecting a conduit or wiring.
- If the operating atmosphere is contaminated, use a protective cover to prevent the entry of foreign objects into the interlock switch through the actuator entry slots.
- Entry of a considerable amount of foreign objects into the interlock switch may affect the mechanism of the interlock switch and cause a breakdown.
- Plug the unused actuator entry slot using the slot plug supplied with the interlock switch.
- Do not store the interlock switches in a dusty, humid, or organic-gas atmosphere, or in an area subjected to direct sunlight.
- Use dedicated actuators only. When other actuators are used, the interlock switch may be damaged.
- Do not modify the actuator, otherwise it will damage the interlock switch.
- The cover uses special screws which cannot be removed or tightened by general drivers. Use the special wrench supplied with the interlock switch (HS1B).
- Regardless of door types, do not use the interlock switch as a door lock. Install a separate lock using a latch or other measures.
- The solenoid has polarity. Make sure of the correct polarity when wiring. Do not apply overvoltage, otherwise the solenoid will be burnt.

Actuator Angle Adjustment

- Using the angle adjustment screw, the actuator angle can be adjusted (refer to the dimensional drawing). Adjustable angle: 0 to 20°
- The larger the adjusted angle of the actuator, the smaller the applicable radius of the door opening.
- After installing the actuator, open the door. Then adjust the actuator so that its edge can be inserted properly into the actuator entry slot of the interlock switch.
- Recommended tightening torque of angle adjustment screw: $0.8 \text{ N}\cdot\text{m}$
- After adjusting the actuator angle, apply Loctite to the adjustment screw so that the screw will not loosen.
- Actuator retention force is 1500N (static load). Make sure larger force is not applied. When larger force is expected, add a system using interlock switch without lock (ex. HS1B) and sensor in order to detect door opening and to stop the machine.

Minimum Radius of Hinged Door

- When using the interlock switch on hinged doors, refer to the minimum radius of doors shown below. When using on doors with small minimum radius, use the angle adjustable actuators (HS9Z-A3).

Note: Because deviation or dislocation of hinged door may occur in actual applications, make sure of the correct operation before installation.

HS9Z-A2 Actuator

- When the door hinge is on the extension line of the interlock switch surface:

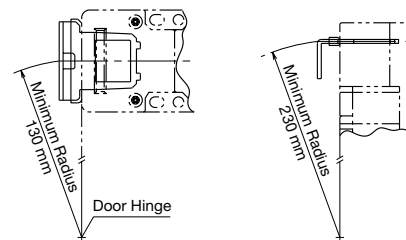

- When the door hinge is on the extension line of the actuator mounting surface:

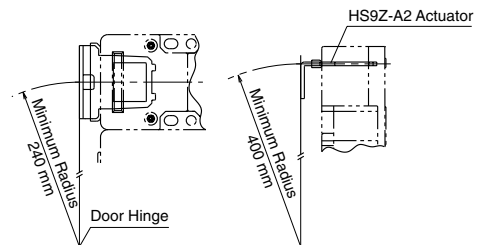

HS9Z-A3 Actuator

- When the door hinge is on the extension line of the interlock switch surface:

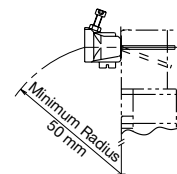

- When the door hinge is on the extension line of the actuator mounting surface:

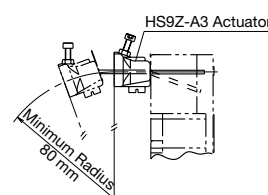

HS1C Interlock Switches with Solenoid

Instructions

Mounting Examples

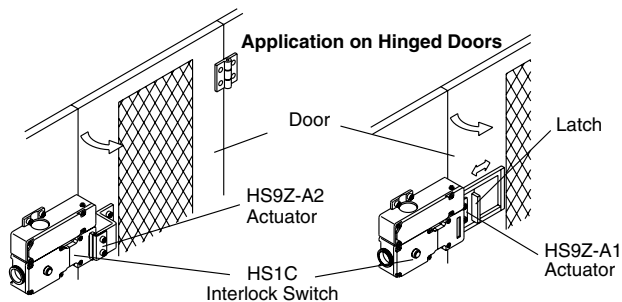
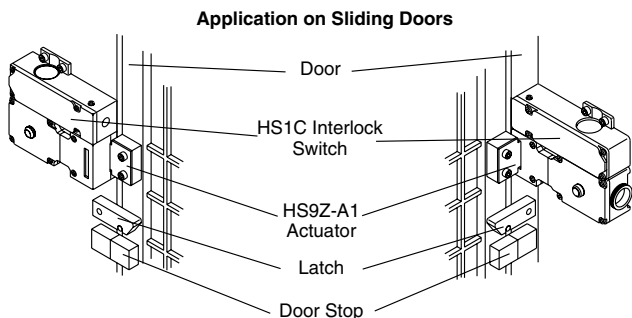

Manual Unlocking

The HS1C allows manual unlocking of the actuator to pre-check proper entry of the actuator into the slot as well as for emergency use such as a power failure.

- Remove the screw located on the side of the interlock switch using the special wrench supplied with the interlock switch. Insert a small screwdriver into the screw hole to push the lever inside of the interlock switch toward the indicator until the actuator is unlocked.

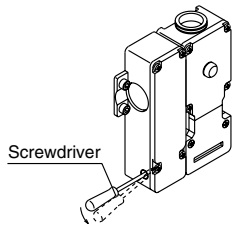

Note: Before manually unlocking the interlock switch, make sure that the machine has come to a complete stop. Manual unlocking during operation may unlock the interlock switch before the machine stops, and the function of interlock switch with solenoid is lost. After unlocking, ensure to install the screw.

Applicable Crimping Terminal

Terminal Nos. 7, 8

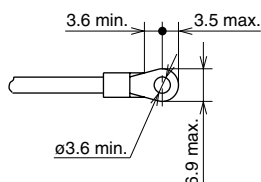

Ground Terminal: E

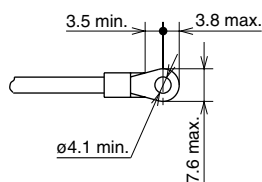

- Use an insulation tube on the crimping terminal.

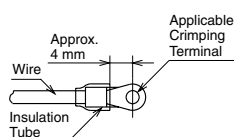

Terminal No. 1 to 6

- Direct wiring using either solid or stranded wires.
- When using stranded wires, make sure that loose wires do not cause short circuit. Also, do not solder the terminal to prevent loose wires.

When using Ferrules

Ferrules (Phoenix Contact)

Part No.	Applicable Wire
AI 0.75-8 GY	0.5 to 0.75 mm ²
AI 1.0-8 RD	0.75 to 1.0 mm ²
AI 1.5-8 BK	1.0 to 1.5 mm ²

Crimping Tool: CRIMPFOX UD6

Applicable Wire Size

- Terminal Nos. 1, 2, 5, 6, 7, 8: 0.5 to 0.75 mm²
- Terminal Nos. 3, 4, E: 1.0 to 1.25 mm²

Applicable Cable Glands

- Use IP67 cable gland.

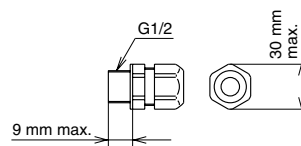

When Using Flexible Conduits (Example)

- Flexible conduit example: VF-03 (Nihon Flex)
- Metal conduit example: (G1/2) RLC-103 (Nihon Flex)

When Using Multi-core Cables (Example)

- Plastic cable gland: (G1/2) SCS-10* (Seiwa Electric)
- Metal cable gland: (G1/2) ALS-16 (Nihon Flex)
- Different cable glands are used depending on the cable sheath outside diameter. When purchasing a cable gland, confirm that the cable gland is applicable to the cable sheath outside diameter.

Recommended Tightening Torque of Mounting Screws

- Interlock switch: 4.5 to 5.5 N·m (four M5 screws)
- Terminal screws for terminal No. 1 to 6: 0.4 to 0.6 N·m (M3)
- Terminal screws for terminal No. 7 and 8: 0.9 to 1.1 N·m (M3.5)
- Actuator (HS9Z-A1/A2/A3): 4.5 to 5.5 N·m (two M6 screws)
- Mounting bolts must be provided by users.
- The above recommended tightening torques of the mounting screws are the values confirmed with hex socket head bolts. When other screws are used and tightened to a smaller torque, make sure that the screws do not come loose after mounting.
- To avoid unauthorized or unintended removal of the interlock switch and the actuator, it is recommended that the interlock switch and the actuator are installed in an unremovable manner, for example using special screws, rivets, or welding the screws.

HS1C Interlock Switches with Solenoid

Instructions

Cable Lead-in Length and Wiring Examples

	Terminal No.	Conduit Port	
		①	②
Cable Length L1 (mm)	1	30±2	45±2
	2	30±2	50±2
	3	25±2	55±2
	4	25±2	60±2
	5	30±2	65±2
	6	30±2	70±2
	7	65±2	35±2
	8	65±2	110±2
	E	85±2	45±2
Wire Stripping Length L2 (mm)		7±1	

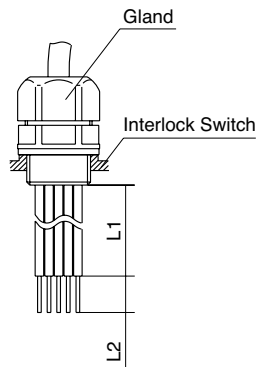

Note: Wire the interlock switches according to the following examples.

When using Conduit Port ①

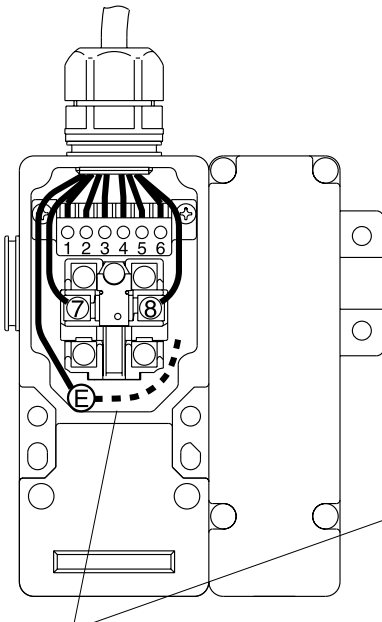

When using Conduit Port ②

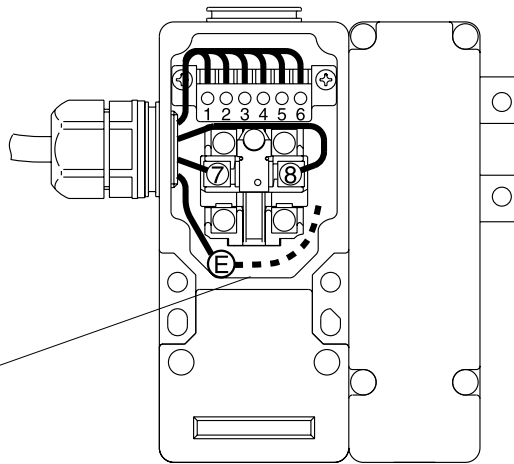

Note: When wiring the ground (E) terminal, connect in the solid line direction only. Do not connect in the dotted line direction.